



SOUTHERN SPORTMOD - 2010

Revised November, 2009. Revisions/clarifications underlined, recommendations italicized. Refer to Official 2010 IMCA Rule Book or www.imca.com for General Rules.

IMCA
1800 West D Street
P.O. Box 921
Vinton IA 52349-0921
319-472-2201 24-hour fax 319-472-2218
www.imca.com
raceimca@imca.com

The rules and/or regulations set forth herein are designed to provide for the orderly conduct of racing events and to establish minimum acceptable requirements for such events. These rules shall govern the condition of all events, and by participating in these events, all participants are deemed to have complied with these rules. NO EXPRESSED OR IMPLIED WARRANTY OF SAFETY SHALL RESULT FROM PUBLICATIONS OF OR COMPLIANCE WITH THESE RULES AND/OR REGULATIONS. They are intended as a guide for the conduct of the sport and are in no way a guarantee against injury or death to a participant, spectator or official. The race director shall be empowered to permit reasonable and appropriate deviation from any of the specifications herein or impose any further restrictions that in his opinion do not alter the minimum acceptable requirements. NO EXPRESSED OR IMPLIED WARRANTY OF SAFETY SHALL RESULT FROM SUCH ALTERATION OF SPECIFICATIONS. Any interpretation or deviation of these rules is left to the discretion of the officials. Their decision is final.

- SAFETY EQUIPMENT:** Rules apply at all times car is on track. Snell-rated SA2000, SA2005 or SFI 31.1/2005 helmet required. Roll bar padding required in driver compartment (*Fire retardant recommended*). SFI-approved full fire suit required. Fire retardant gloves, shoes and neck brace (or head and neck restraint) required. Right and left seat head supports required if using head restraint system with no neck collar. *Recommended: Fire retardant head sock and underwear; collapsible steering shaft.* Driver-side window net required, minimum 16 inch by 20 inch ribbon or mesh style, and must be mounted to roll cage so latch is at top front of window. Minimum three inch (two-inch with head restraint system) wide SFI-approved five point safety belt assembly required (Y-type shoulder harness not allowed), must be mounted securely to roll cage, *recommended to be no more than one year old*. Kill switch required within easy reach of driver and must be clearly marked 'OFF' and 'ON'.
- FRAME:** 1978-1987 OEM midsize GM metric full frame only. Minimum wheelbase 107-inches, maximum 109-inches, both sides. Frame must be full and complete, cannot be widened, narrowed, shortened, lengthened, or be cut, bent, or altered to change suspension brackets, except upper control arm brackets on front end. All frame bolt holes must remain in OEM location. Front frame horns may be removed in front of steering box. Front frame may be cut for radiator clearance. Frame may be notched for seat clearance. Transmission crossmember mounts may be removed, no further forward than frame welds. Rear of frame, behind upper shock mounts, may be replaced with round, square, or rectangular tubing. No part of frame can be lower than five inches from ground except front crossmember. No other frame alterations allowed. See www.imca.com for OEM frame dimensions.
- ROLL CAGE:** Must consist of continuous hoops, minimum 1.5 inch O.D. tubing, with a minimum wall thickness of .095 inch for main cage. Cages must be steel or chrome-moly. Main cage no further forward than rear of engine and no further back than front edge of rear tire. Four bars, two per side, may extend from main roll cage to main frame points in front of the upper control arms. These bars may have two additional braces per side to the main frame. Six bars may extend from the main cage to the rear. X-bracing is allowed. Driver's head must not protrude outside cage with helmet on. Roll cage must be securely supported and braced with minimum one cross bar in top halo. All bars forward of cage must be lower than hood.
- DOOR BARS:** Minimum three driver side door bars required, minimum 1.5 inch O.D. and .083 inch wall thickness, must be parallel to ground and perpendicular to driver, and welded to front and rear of roll cage. Minimum two passenger side door bars required, must have at least one cross door bar, horizontal or angled. Steel door plate, 18 gauge or .049-inch.
- BODY:** (See diagram) Must be same width, front to rear, and parallel to OEM frame. Nose panel must be flat with no fins or scoops allowed. Cooling holes allowed. Nose panel may be no wider, or lower than two inches outside of front frame horns. Nose panel must remain within confines of front bumper. Engine compartment must remain open (no side panels). Aluminum or fiberglass hoods allowed, must completely cover top of radiator and engine, extending from nose to interior deck and enclosed at rear. Must have front and rear roof supports. Roof must be fiberglass or aluminum, full size and rounded down in all directions (see diagram). No dish roof allowed. Driver roof hatch allowed. No plastic body panels or filler panels allowed. Must have complete interior deck from side to side, must be aluminum or sheet metal. Quarter panels must remain 90-degrees to ground, maximum 45-degree bend 4-inches from bottom and 2-inches from top of doors and quarters. Rear spoiler may be maximum 8 inches in material height and maximum 67 inches wide. Spoiler may have stiffener, must be 1 inch or more down from top. Maximum 3 spoiler braces allowed, must be mounted in line. Spoiler braces must resemble all aspects of drawing and must be separate from sail panels. No fins, lips or wings allowed.
- DRIVER COMPARTMENT:** Must have minimum three 5/16 inch O.D. windshield bars in front of driver. Aluminum cowl panel in front of driver can be no wider than cockpit. Aluminum high-back seat only, must be securely bolted, using minimum 0.375-inch bolts, to roll cage and support system. Floor pan must be metal or aluminum and cover entire driver compartment. Bottom of seat can be no lower than bottom of frame rail. Driver must be sealed off from track, driveline, engine, fuel cell, canisters and pumps. No oil coolers allowed in driver compartment. No devices that would enable driver adjustment to alter wheelbase or for weight jacking while car is in competition. No mirrors of any kind.
- FRONT SUSPENSION:** All components must be steel, unaltered OEM, in OEM location, and match frame. No jack bolts allowed. Adjustable spring buckets are allowed. Must use OEM upper and lower A-frames and mounts. OEM upper A-frame may be replaced using aftermarket upper A-frame (steel or aluminum cross shaft allowed), must display "IMCA approved" decal. Upper A-frame mounts may be modified and moved for caster and camber adjustment, but must remain OEM material. Lower A-frame mounts and bolt holes on frame must be in OEM location, mount may be notched for clearance. All A-frame bushings may be aftermarket, but no offset or bearing type. OEM or OEM replacement ball joints allowed, may be tacked in. Sway bars (optional) and brackets must remain OEM.
- STEERING:** All components must be steel, unaltered OEM, in OEM location and match frame. No grinding, lightening or welding on any steering parts. Spindle may be reamed and bolt on spindle savers are allowed. Steel steering shafts and knuckles only. Steering quickener (optional), steering wheel and quick release (required) may be aluminum. Power steering pump and reservoir must remain one unit. Driver compartment steering may be modified, must be kept on left side. No rack and pinion.
- SHOCKS:** One steel shock per wheel only. Shock must be in OEM mounts and location, using OEM style shock. Mounting spacers and weld or screw-on shock ends allowed. No air or coil-over shocks, remote reservoir shocks, Schrader valves or bladder type valve allowed. One or all shocks may be claimed per event for \$50 each, counting as one claim on card, following shock claim procedures (Refer to IMCA Operations and Inspection Manual or www.imca.com).
- SPRINGS:** One steel spring (racing allowed) per wheel only. Minimum 4.5-inches O.D., non-progressive coils only. No torsion bars or air bags.
- REAR SUSPENSION:** All control arms and mounts must be steel, unaltered OEM, in OEM location, and match frame. No jack bolts allowed. Adjustable spring buckets allowed, may be dropped as long as they remain in OEM location. If upper spring cup uses all thread, it must be securely welded to chassis. Lower spring cups must be centered on housing. Control arms may be reinforced, but cannot be shortened or lengthened, must remain OEM length. All control arm bushings may be aftermarket, but no offset or bearing type. Bushings cannot be drilled. No suspension parts may be altered or lightened. No aluminum parts allowed, other than bushings.
- REAR END:** Must use OEM 7.5-inch GM 10 bolt rear end (bracing optional), must remain stock width. No Ford or floater rear end allowed. Housing end, from control arm mount out, may be modified with 3-inch tubing to accept 9" Ford axle. If Ford axles are used, rearend must remain minimum GM width or maximum 3-inches wider. Steel components only. OEM mounts on lower control arms must remain in OEM location on original 7.5-inch tube housing. Aftermarket axles, mini-spools and C-clip eliminators allowed. Locked rear ends only, no torque dividing differentials allowed. No full or aluminum spools allowed. Pinion angle can not be changed. Any gear ratio allowed but housing must remain unaltered. No quick change devices.
- BUMPERS/RUB RAILS:** Steel only. Two bar front bumper and single bar rear bumper must be used on car at all times and welded, or bolted securely using minimum 0.375 inch bolts. Must be maximum 1.50-inch O.D. tubing, .095-inch wall thickness on front and 1.75-inch tubing, .095 wall thickness on rear. Maximum 1.50-inch O.D. tubing, .095-inch wall thickness fuel cell protection bar required, must cover rear and extend past both sides of cell, may be welded to rear bumper. See diagram for bumper heights. Rear bumper may be maximum 6-inches beyond rear deck. All bumpers and rub rails must be capped with no sharp edges. Single bar rub rail from front to rear wheel allowed on each side, no center supports allowed, maximum 1.50-inch O.D. tubing and .095-inch wall thickness, must be mounted to cage at front and rear of rub rail.
- TIRES/WHEELS:** Must use unaltered Hoosier '500' Race tire, with IMCA stamped on sidewall. 27 by 8 by 15 or 26.5 by 8 by 15 'stagger tire' allowed. No chemical softening, conditioning or grooving of tires (Refer to IMCA Operations and Inspection Manual or www.imca.com for automatic penalties). Tires may be ground or siped within confines of tread. All wheels must display white "IMCA approved" decal and wheel manufacturer decal. Any offset allowed. May use IMCA approved bead lock, on right rear only. External steel bead lock only and it cannot make wheel any narrower than 8-inches and no wider than 8.75-inches. Steel bolts only. Foam type or plastic outer mud cover allowed on right side wheels. Inner mud cover allowed on left rear only. No bleeder valves. Must use minimum 1-inch O.D. lug nuts and 0.625-inch studs are recommended. No wheel spacers allowed with OEM studs. Wheel adapters are treated as spacers and may be aluminum, maximum 1.50-inches thick.
- BRAKES:** Must be steel OEM, operative three wheel, drum or disc. Must maintain minimum OEM dimensions for hubs/rotors and calipers, cannot be lightened. Bolt pattern may be changed. 0.625-inch studs allowed. Single or dual aftermarket master cylinders allowed. Driver adjustable dual pedal brake bias allowed. Additional proportioning valve (in-line type) allowed, must be out of driver reach. Rear rotors may be aftermarket, minimum 0.810-inch thickness, maximum 12-inch O.D. Vented rotors only, no scalloped, ceramic coated, single phase or drilled rotors allowed. Rear caliper brackets must be welded to housing.
- EXHAUST:** Must use Schoenfeld headers. GM: #161, #151, #151E with 1.625-inch tubes and 3-inch collector. Chrysler: #451, #461. Ford: #351, #361. No header modifications allowed. No exhaust sensors, merge collectors, cross overs, extensions or balance tubes. Turn down allowed. Coated headers allowed. Schoenfeld mufflers, stamped IMCA609, must be used if track has noise reduction rule of 98 d.b. or more.
- FUEL SYSTEM:** Racing fuel cell required, maximum 22 gallon capacity, must be in minimum 20 gauge steel container. Must mount with minimum two solid steel straps around entire cell, two inches wide and 0.125 inch thick, between frame rails and behind rear axle. Fuel cell vents, including cap vent, must have check valves. If fuel cell does not have aircraft style positive seal filler neck/cap system - a flapper, spring or ball type filler rollover valve is required. No part of cell can be lower than protective tubing. OEM mounted, mechanical push rod fuel pumps only. No regulators, bypass fuel systems, pressurized, or return lines allowed. **CARBURETOR** (one only): Holley (unaltered) #4412 or #0-80583-1, 500 cfm two barrel may be used on any engine (float bowl must face forward). OEM GM Quadrajel or two barrel may be used on GM. OEM Motorcraft four or two barrel may be used on Ford. OEM Carter or AFB four or two barrel may be used on Chrysler. OEM carburetors must remain unaltered, circle track floats may be installed. No other carburetors allowed. Any adapter allowed, maximum 1.250-inches thick, including gaskets. No throttle bore adjustable carburetor spacers. Limit of one fuel filter. No cool cans. Any air cleaner allowed. No cold air boxes or ducting of any kind between engine and hood.
- FUEL:** Gasoline only. Racing fuel allowed. No E85. No performance enhancing additives or scented additives. Fuel must pass both dielectric meter and chemical tests. Fuel sample may be taken from any car at any time (Refer to IMCA Operations and Inspection Manual or www.imca.com for automatic penalties).
- WEIGHT:** Minimum weight limit of 2,350 pounds after race with driver in car. Weights must not be used in driver compartment or outside body. All weights must be securely mounted with at least two, .5-inch bolts, painted white with car number on it. No titanium, magnesium, stainless steel or carbon fiber components. Solid steel fasteners only.
- BATTERY/STARTER:** One 12-volt battery only. Must be shielded and securely mounted. Aftermarket starter allowed, must bolt in OEM location. Must have capability of starting without being pushed or pulled. Must leave initial staging area on demand, unaided, or go to rear of that race.
- GAUGES/ELECTRONICS:** No unapproved cameras, transmitting or listening devices, timing retard controls, or digital gauges (including tach). No electronic monitoring computer devices capable of storing or transmitting information except analog tach. OEM style ignitions only. GM: HEI distributor (must remain one unit) or point distributor allowed. Ford/Chrysler: may use OEM ignition, including OEM boxes, or HEI distributor. Any module allowed that fits inside distributor with no alteration. Vacuum advance may be removed and pick-up coil locked. No external coils allowed, unless using point distributor. No GM or aftermarket ignition boxes allowed. OEM type alternator with

internal regulator allowed. No electronic traction control devices (Refer to IMCA Operations and Inspection Manual or www.imca.com for automatic penalties).

- 22. TRANSMISSION/DRIVE SHAFT:** Only OEM production transmissions allowed. No aftermarket transmissions allowed. No 'in and out' boxes or quick change devices allowed. With engine running and car in a still position, must be able to engage car in gear and move forward, then backward. Functioning shift levers must be in OEM location. Transmission fluid coolers allowed. Flywheel, flexplate and converter must be steel.
- Automatic:** Any OEM automatic transmission allowed. Must use functioning, minimum 10-inch diameter steel torque converter. No direct drives, couplers, valved pumps, or bleeder style valve bodies. Must have at least one forward gear and reverse gear, gears must function. Must have an approved scattershield constructed of .125-inch by three-inch steel, 270 degrees around top of flexplate. GM automatic must be used with GM engine, may be used with Ford or Chrysler engine. Stall converters allowed. Steel OEM style flexplate only, must be bolted directly to end of crankshaft.
- Manual:** 3, 4 or 5 speed OEM manual transmissions only. All gears must function. Must have functioning 10.5-inch minimum diameter clutch and pressure plate bolted directly to steel flywheel. These components must rotate, consistent with engine rpm, while car is in any gear. Must use explosion-proof steel bellhousing 180 degrees around top of clutch and flywheel. No mini-clutches or couplers. Minimum 9-inch diameter Ford clutch allowed. Hydraulic slave cylinder/throw out bearing allowed.
- Drive Shaft:** Minimum 2-inch diameter, white, steel drive shaft only. Steel slip-yokes only. 360-degree drive shaft loop required, constructed of at least 0.125-inch by 2-inch steel, or 1-inch tubing, mounted 6-inches back from front U-joint.
- 23. ENGINE COMPARTMENT:** Rear of engine (bellhousing flange) must be mounted at least 70-inches forward from centerline of rear axle. Minimum 11-inch engine height from ground to center of crankshaft. One radiator allowed, steel or aluminum, 27-inches by 19-inches maximum in size, must be mounted in front of engine. Racing cap and electric fans allowed. No sprinklers. Catch can required. Power steering pump and reservoir must remain one unit and mount in front of engine. Side engine mounts only (OEM or 45-degree style) must be steel, aluminum mid-plate allowed.
- 24. ENGINE SPECIFICATIONS:** All engines must be able to be used in conventional passenger car without alterations. External engine casting and threaded holes cannot be altered. No aluminum, titanium or carbon fiber components allowed.
- BLOCK:** Must use OEM steel passenger vehicle production block only. No GM bowtie, Ford SVO or Chrysler W-2 components allowed. Approved blocks are: GM (Chevy only): 283, 302, 305, 307, 327, 350. Ford: 260, 289, 302, 351. Chrysler: 273, 318, 340, 360, no hemis. Maximum cubic inch limits: GM 364, Ford 360, Chrysler 370, no tolerance. Violation of cubic inch limit must be verified by removal of head and will result in disqualification, loss of all IMCA points for the season, \$1,000 fine and a 30-day suspension. No 400 or larger cubic inch parts allowed. Any flat top or dished pistons allowed, no gas ported pistons. 3.48-inch maximum GM stroke. Maximum 175 lbs. per cylinder compression, no tolerance. Compression checked with one spark plug removed, turned five engine compression revolutions. Engines may be balanced and block decked. Oil filter system must remain OEM. 'Wet' sump oiling system only. No accumulators. OEM or OEM replacement steel crankshaft only - cannot be lightened (no aerowing, bullnose, knife edge, undercut or drilling of second or third rod throws allowed). OEM or OEM replacement steel rods only - GM must use maximum 5.7-inch rod. No cap screws. No splayed main caps. Racing oil pans allowed. Mandatory one inch inspection hole in all pans - no obstructions to crank and rods. Engine bolts may be aftermarket. Fluid dampener balancer allowed. No roller bearings allowed.
- CYLINDER HEADS:** Steel only. GM OEM approved head numbers are (last 3 digits): 126, 185, 336, 441, 445, 487, 487X, 493, 598, 624, 862, 882, 920, 993, 997, with valve no larger than 1.94-inch intake and 1.50-inch exhaust. May use Engine Quest (EQ) Stock Replacement (SR) cylinder head, part number CH350I, head must remain as produced, seat angles and valve sizes can not be changed: three angle valve job only (absolutely no casting removal in valve pocket of EQ head, for any reason). No porting, polishing, or unapproved alterations to ANY cylinder head. Any cast iron OEM Ford and Chrysler heads allowed with valves no larger than 2.04-inch intake and 1.70-inch exhaust. Headers must bolt directly to heads with correct numbers. No vortec, bowtie, SVO, W-2 or aftermarket heads allowed. Flat milling allowed. Guide plates, screw-in shouldered studs (0.375-inch max) and polylocks allowed. No stud girdles. Stamped steel, OEM style, stud mounted (0.375-inch max) rocker arms only. Chrysler may use OEM rocker arm bars. Any length push rods allowed. OEM diameter springs (GM - 1.250 inch maximum O.D.) must match heads, no beehive valve springs allowed.
- INTAKE:** Unaltered, approved OEM cast iron low rise, two- or four-barrel. Only unaltered aftermarket aluminum intakes allowed are: Weiland GM #7547-1; Ford #7515, #8023 or #7516; Chrysler #7545; Edelbrock GM #2701; Ford #7121, #7181, #7183; Chrysler #2915. No porting, polishing, or plenum alterations to ANY intake. Cooling lines allowed on aluminum intakes. Disqualification, loss of points, purse and \$250 fine if any alterations are found to heads/intake. No OEM hi-rise, marine or bowtie intakes. Ford may use OEM aluminum intake, no under air or hi-rise. All intakes must have unobstructed 0.250-inch vacuum fitting. Belt driven, OEM style water pumps only, no aluminum water pumps on GM engine.
- CAMSHAFT:** Non-roller hydraulic cam/lifters only, cannot alter lifter bores. OEM firing order cannot be changed (GM: 1-8-4-3-6-5-7-2). Hydraulic lifters must remain UNALTERED OEM. No maximum cam lift. Must pull 12-inches of vacuum at 1200 rpms. Vacuum must be pulled on intake vacuum fitting, not carburetor. No alterations of any kind may be made at time of tech. Track equipment being used for tech is final. Lifter bores cannot be altered. Must be chain driven, no gear/belt drives.
- 25. ENGINE CLAIMING RULES:** Refer to IMCA Operations and Inspection Manual or www.imca.com for claim eligibility requirements.
- (A) \$550 cash and exchange claim on engine (\$25 goes to wrecker and \$25 to official for each engine)
- (B) Claim does not include - 1. flywheel, 2. clutch, 3. pressure plate, 4. bellhousing, 5. breathers, 6. carburetor, 7. starter, 8. motor mounts, 9. oil/temp. sending units, 10. fan and pulleys, 11. clutch ball, 12. clutch arm, 13. throw out bearing, 14. dip stick, 15. water pump, 16. fuel pump, rod and plate, 17. distributor, 18. plug wires, 19. water outlet and restrictor, 20. headers.
- NOTE:** During engine claim, block and head numbers should be verified, inspect heads and intake, and one spark plug must be removed to check pistons prior to transfer of engines. If, at this time, an engine is found illegal, driver is disqualified and suspended from all IMCA sanctioned events until such time as a \$250 fine is paid, for first offense. Exchange of engines may proceed depending on circumstance. Decision to proceed is at discretion of track officials and/or IMCA.
- 26. ENGINE PROTEST PROCEDURES:** Within 5 minutes after race, any driver starting feature may, for \$250, protest any engine. \$50 of the protest fee goes to track and will not be refunded, regardless of protest outcome. Driver may not protest another driver finishing in a position behind them and may not protest same driver more than once per calendar year. Under this protest, following **MUST** be inspected: intake manifold, cylinder head (removal required), stroke, and visual inspection of crankshaft (pan may be removed). \$200 will be returned to protestor if engine is found illegal. If engine being protested is found legal, \$200 protest fee will be paid to driver being protested. If parts are found illegal, or if driver refuses to submit to protest, first infraction will result in forfeiture of all cash and contingencies, trophies and points earned in feature.
- 27. POINT STRUCTURE /PROCEDURES:** Refer to IMCA Operations and Inspection Manual or www.imca.com for automatic penalties.
- 28. EIRI:** (Except in rare instances) Decisions of officials are final and binding without exception. In some cases, track safety rules may take precedence over IMCA rules - any discrepancy between IMCA and track rules should be brought to the attention of IMCA. Any rule changes or clarifications during the course of the year will be amended on www.imca.com as well as published in **Inside IMCA**, the official newsletter of IMCA, and will be considered as an official part of these rules.

For more information, call Tom Gutowski at 402-350-6120, or IMCA at 319-472-2201.

Copyright© 2010 IMCA All rights reserved.

No part of this publication may be reproduced, stored, or transmitted in any form, without prior written permission.

IMCA Southern SportMod Dimensions For 2010

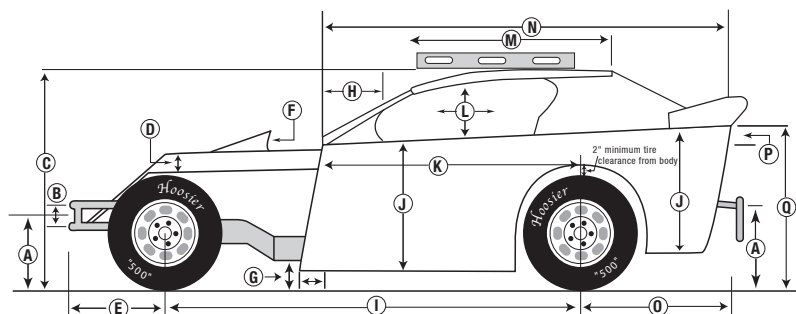

All body measurements are max. unless otherwise specified. Dimensions have zero tolerance.

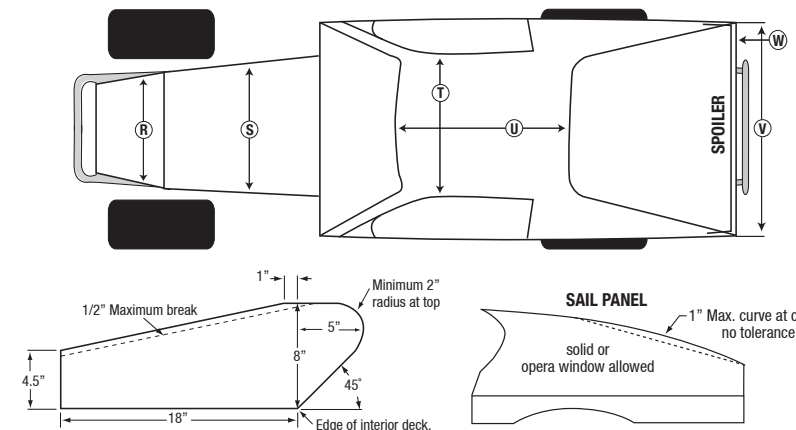

- A** 23" max. 16" min. (ground to center of bumpers, front and rear)
- B** 6.5" min. (center to center)
- C** 58" max. 42" min.
- D** Hood 5" max. drop (sides), sealed off from driver's compartment and max. 3" rake.
- E** 42" max.
- F** 6" max.
- G** 5" min. to frame rails. Door may be extended maximum 6" past block at bottom on both sides.
- H** 19" max., must be same on both sides.
- I** 109" max. 107" min.
- J** 31" max. 22" min.
- K** 67" min., or not past back of block at top.
- L** 18" max. 12" min. opening, both sides.
- M** With level, must have no more than 2" clearance at rear of roof and 5" at top front.
- N** 121" max. 98" min.
- O** 48" max. 31" min.
- P** Interior slope is 6" max. front to rear and flat across. If flat at front half of interior you have used up 50% of your 6" so from behind driver to rear you may only have 3". Top of interior must be flush with top of doors and quarters. Optional escape hatch from driver to passenger door allowed.
- Q** 41" max. 28" min.
- R** Max. no wider or lower than front frame horns, min. 24" nose must flat and flush with sides.
- S** 67" max. 24" min., must cover radiator.
- T** 53" max. 32" min.
- U** 53" max. 32" min.
- V** 67" max. 55" min., measured at top of interior deck, must be same front to back.
- W** IMCA decal required on car.

REAR FILLER PANEL OPTIONAL
SPOILER BRACES: Maximum 3 total. Bottom edge of spoiler brace must be flush with rear edge of interior deck.
SAIL PANELS: Must be within confines of these dimensions and the same on both sides. Must mount within 2" of outside edge of interior deck.